

VERICUT®

CNC Machine Simulation Software

***Right the first time.
Every time.***

CGTECH.co.uk

Software for:

Workpiece Verification
CNC Machine Simulation
NC Program Optimization
Additive Manufacturing
Automated Composites
Drilling & Fastening

WHY VERICUT?



CRASH DETECTED!

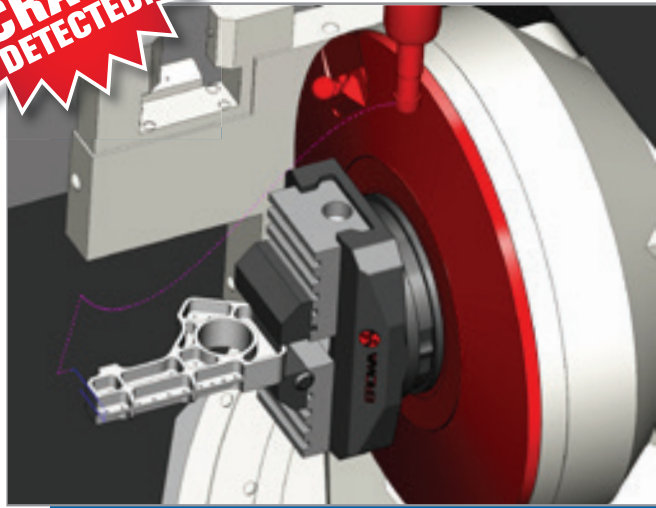

Why VERICUT?

VERICUT CNC simulation software **simulates from the actual posted NC program**, which catches mistakes you cannot find in CAM simulations. Combined with the most accurate cut stock model in the industry, this enables you to virtually machine parts and identify mistakes and inefficiencies before any actual cutting occurs. You can eliminate errors that could ruin the part, damage the fixture, break the cutting tool, or crash the machine. VERICUT also optimizes NC programs to make them faster and more efficient.

VERICUT simulates from the actual posted NC program, which catches mistakes you cannot find in CAM simulations!



Why CGTech?

Team up with the largest group of CNC machining experts in the world.

- *Founded in 1988, CGTech is privately held and 100% self-financed*
- *Your CGTech contacts work closely with VERICUT developers to best support your needs*
- *Core products are developed in-house, which allows for quick customization*

VERICUT®

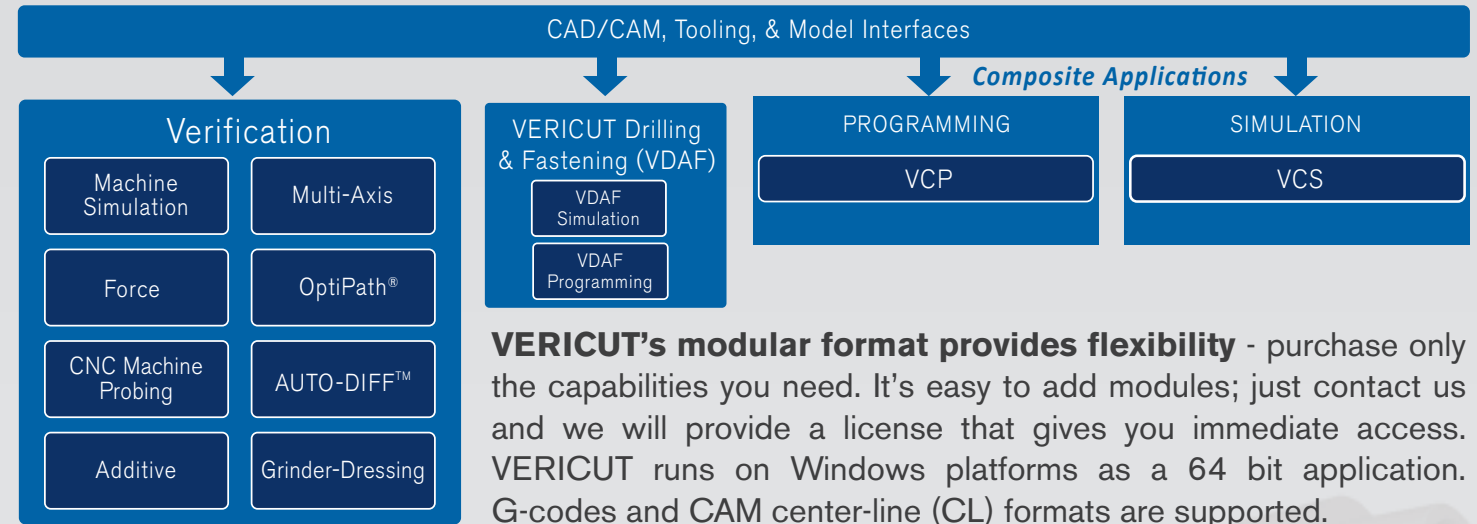

VERICUT's modular format provides flexibility - purchase only the capabilities you need. It's easy to add modules; just contact us and we will provide a license that gives you immediate access. VERICUT runs on Windows platforms as a 64 bit application. G-codes and CAM center-line (CL) formats are supported.

Three Steps to Run VERICUT:

1. Define your stock model
2. Set up your tooling
3. Import your NC program

Then press Cut. It's that simple!

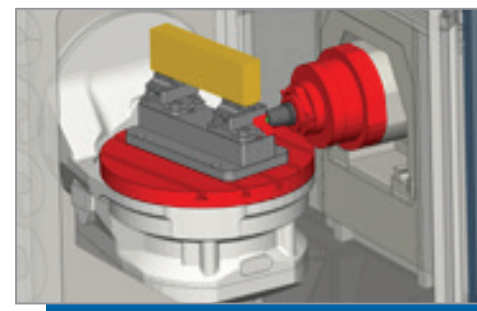
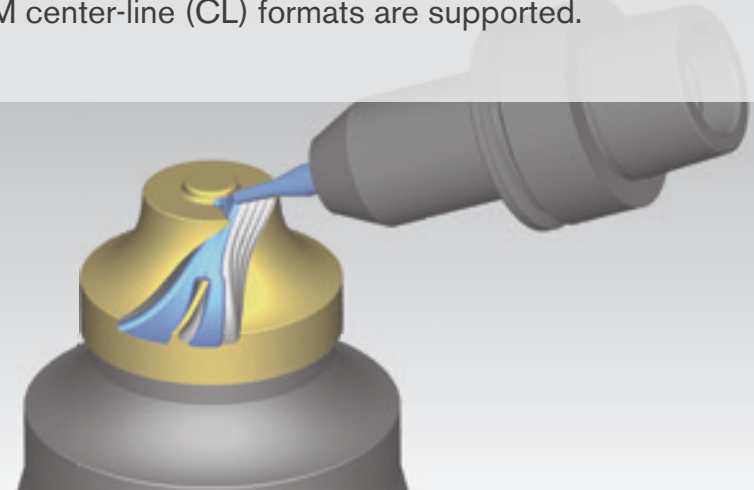

A crash on a VERICUT "virtual machine" can save your real machine!

Workpiece Verification & Reviewer.....	4
Multi-Axis & AUTO-DIFF.....	5
CNC Machine Simulation.....	6
NC Program Optimization.....	8
Probing & Model Export.....	9
Additive Manufacturing.....	10
Composite Applications.....	11
Drilling & Fastening.....	12
Vericut Machine Configuration (VMC).....	13
CAD/CAM Interfaces.....	14
Training & Services.....	15

SAVE TIME • SAVE MONEY
SAVE YOUR MACHINES

"VERICUT paid for itself the first time we used it"

– Dave Watson, Manufacturing Eng., Lockheed Martin Aeronautical Systems

WORKPIECE VERIFICATION

Easily detect program mistakes and verify part accuracy with the VERICUT base module: Verification.

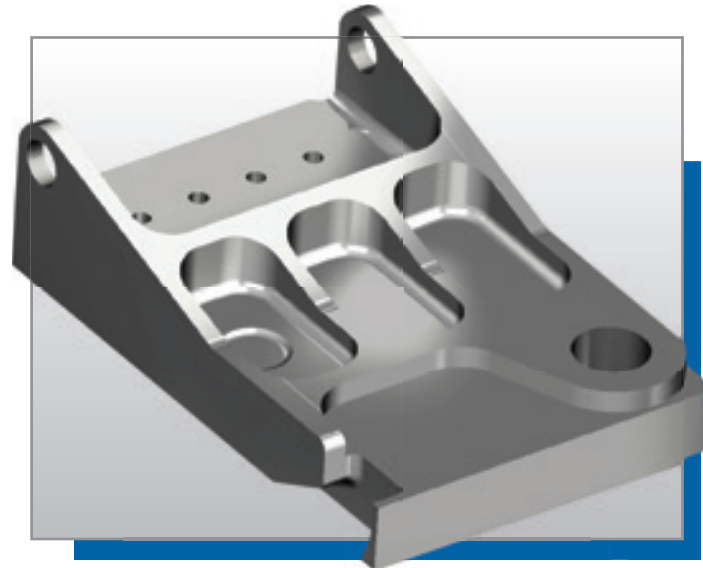

Workpiece Verification

Mistakes happen. VERICUT catches them. VERICUT reads the same post-processed G-code as your machine tool, and detects errors before they can damage your machine.

- Accurate NC program error detection & reporting
- Prevents collisions and broken tools
- CNC control emulation & G-code support
- More accurate than STL/Polycut technologies
- View, measure & analyze the geometry of the cut part
- Supports multi-axis CNC machines & most common control functions



VERICUT Reviewer

With the VERICUT Reviewer, shop floor personnel, suppliers, customers, and other production engineers can view animations of the simulated CNC machining process from any location. No license required.

- View CNC machine simulations from any location
- Package reports for a virtual workshop document

MULTI-AXIS & AUTO-DIFF™

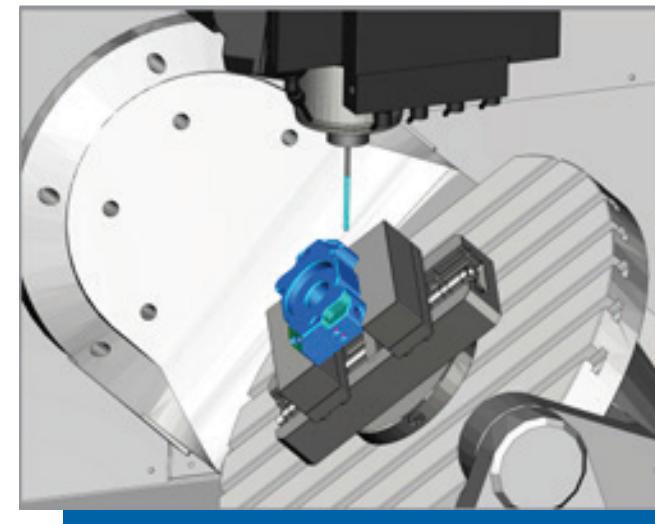

Multi-Axis

The Multi-Axis module verifies and simulates material removal on multi-axis mills, lathes, mill/turns, or multi-head machines. As complexity increases, so does the chance for error. Don't leave the accuracy of the NC program, the quality of the part, or the safety of the operator to chance!

- Accurately verify & simulate complex machining
- Be certain your complete process is error free
- A must if you perform 4 and 5 axis machining!

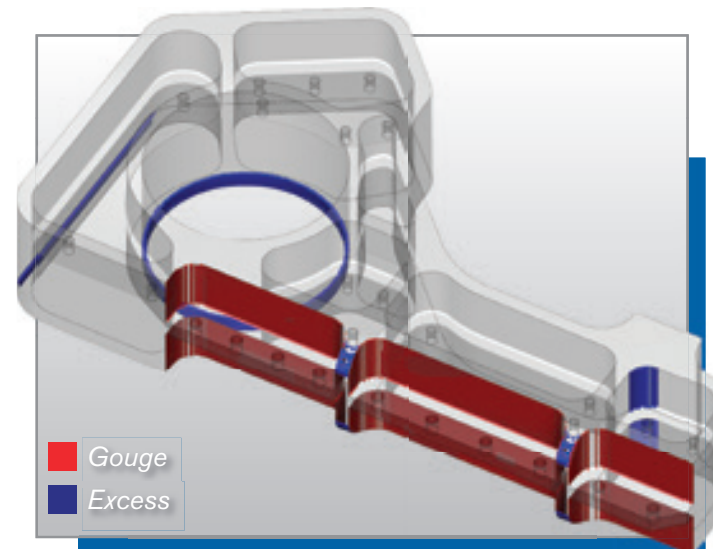

AUTO-DIFF™

The AUTO-DIFF™ module detects gouges and excess material by comparing the design model to the "as-machined" model. With AUTO-DIFF™, you can be sure a tool path represents the intended design before the first chip is made.

- Detect gouges & excess material
- Compare cut model to CAD model
- Identify overcuts and undercuts

"VERICUT is one of the most powerful and underutilized tools available today."

– Gary Wills, Director of Mfg., D&H Manufacturing Company

"VERICUT saved us \$30,000 on one part alone."

– John Sweeney, NC Programmer, Schmiede Corporation

MACHINE SIMULATION

Simulate your CNC machines, exactly as they behave on the shop floor, so you can detect errors and problems.

Eliminate Prove-outs!



COLLISION CHECKING & GRINDER-DRESSING

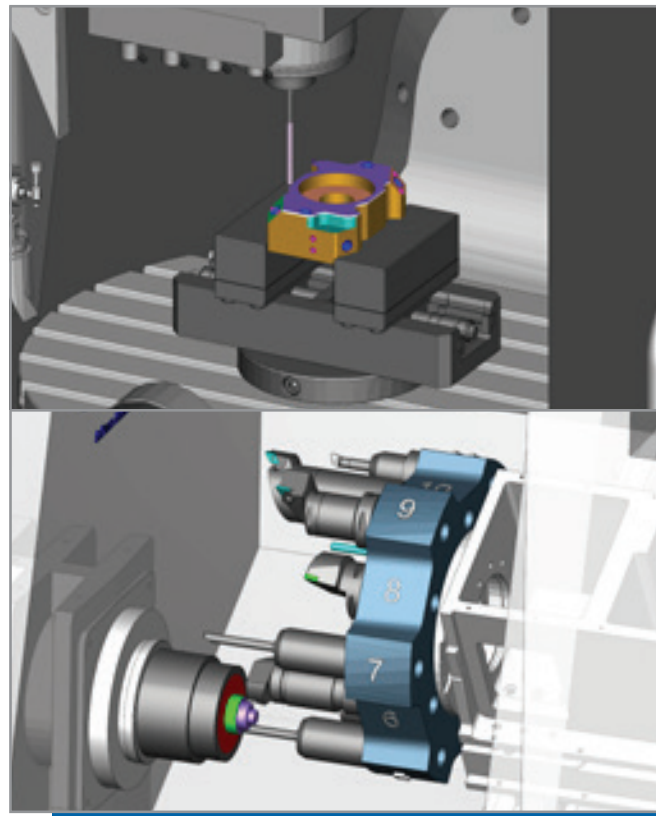

Machine Simulation

A crash can ruin your machine and delay your entire schedule! With VERICUT, you can dramatically reduce the chance for error and avoid wasting production time proving-out new programs on the machine. Machine Simulation detects collisions and near-misses between **ALL** machine tool components.

- Prevent CNC machine collisions and near-misses
- Visualize the full machining environment
- Check CNC machine capabilities and reduce the time it takes to implement a new machine
- Show machinists what to expect from new programs
- Improve process efficiency
- Increase shop safety
- Enhance presentations and documentation with AVI simulations
- Train without using production time (or risking a crash)

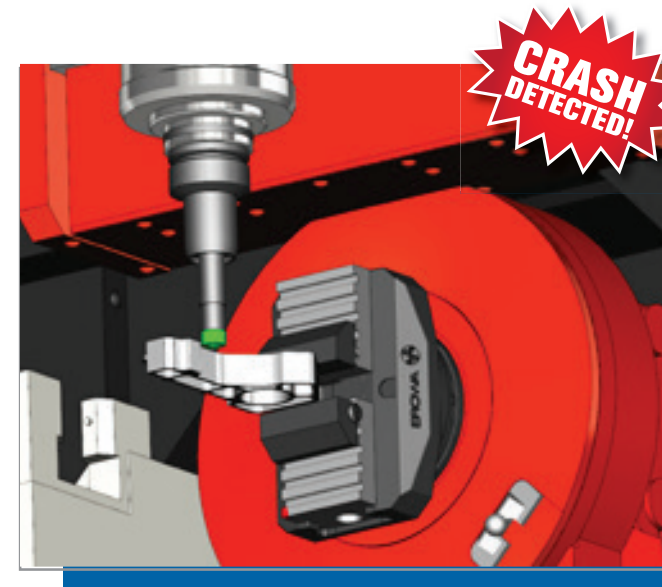

Superior Collision Checking

VERICUT features the most accurate collision checking available, no matter how complex the NC programs are. Rather than just checking points along a path, VERICUT checks along the entire path of travel by sweeping through space. VERICUT was designed by NC simulation & verification programmers and professionals, which makes it an excellent tool when using multi-axis machines, complex NC codes, and/or advanced programming techniques.

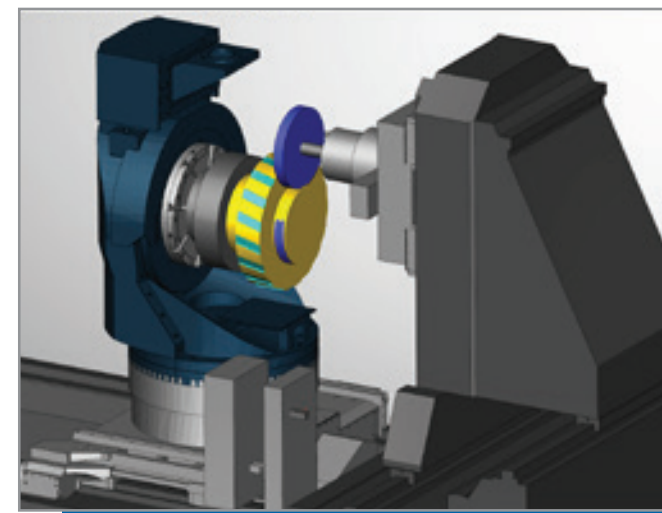

Grinder-Dressing

The Grinder-Dressing module offers superior G-Code simulation for grinding operations with a dressed grinding wheel. As the grinding wheel size is reduced, the machine components get closer to the part, creating a high risk of collision. VERICUT checks the clearance between the machine components and the part to be machined for potential collisions. VERICUT accurately checks for errors on all 5-axis milling and turning processes no matter how complex the machining operation.

Do you know how much prove-outs are costing you?

In today's competitive manufacturing environment, software verification is essential to your ability to produce on-time, high quality goods at a reasonable cost. In the conservative example to the right, prove-outs cost £16,800 a month. This does not factor in additional costs such as scrapped or damaged parts, broken tooling, damaged fixtures, and extra machine tool maintenance. What are prove-outs costing you?

x	12	Number of machines
x	10	Hours per day
x	20	Days per month
x	10	% of time proving programs
=	240	Hours spent
x	£70	Hourly machine cost
=	£16,800	Monthly, or
	£201,600	Annual prove-out cost

"The use of VERICUT Machine Simulation has been a critical factor in the successful implementation of our new 5-axis machines."

– Bill Taylor, Production Engineering Mgr., Aerostructures Hamble, LTD

"Before VERICUT, we were having difficulty getting first-time programs through the shop. Now we're quickly approaching our goal of an 80% perfect part ratio on all first-time programs."

– Creg Crones, Programming Dept. Mgr., ProCam Machine

NC PROGRAM OPTIMIZATION

Force is a physics-based module that analyzes and optimizes cutting conditions throughout program operations.



PROBING & MODEL EXPORT

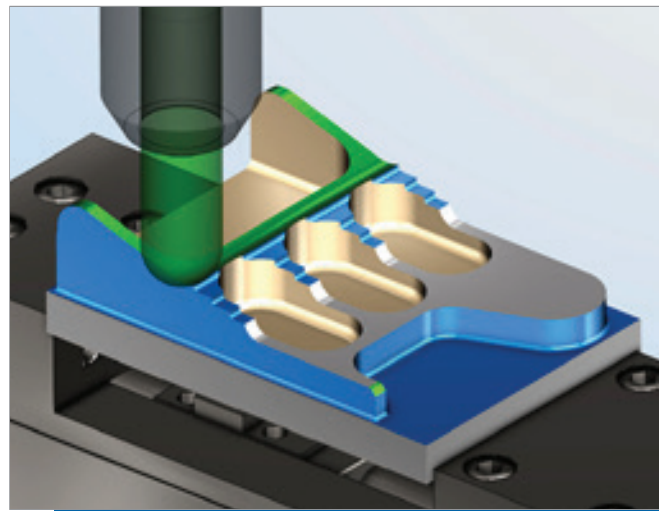

Force

VERICUT Force makes the most effective NC programs for a given material, cutting tool, and machining conditions. The result is **significant cycle time savings, improved surface finish, increased machine life and reduced tool wear.**

- Reduce machining time by 15-25%
- Effective with ANY CAM system and ANY NC program
- Improve cutting tool performance
- Maximize productivity and savings
- ANY tool, ANY material

ALL NC programs, old or new, can be optimized with Force to run as efficiently and safely as possible

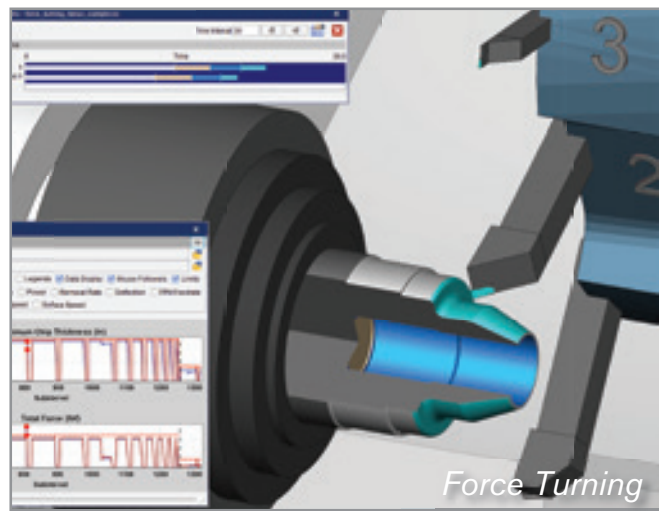

Analyze

With VERICUT Force, NC programmers can quickly and easily visualize what is happening cut-by-cut in the NC program as the tool contacts the material. VERICUT Force lets you see underutilized cutting conditions, excessive forces, metal removal rates, power, torque, and tool deflections.

A single click provides a review of the NC program and a visual analysis in the graphic review window. This analysis provides a view of the machining before running the NC program on the actual machine. VERICUT Force provides the user with a proactive analysis of NC programs, making them right the first time.

See cgttech.co.uk for information on VERICUT's additional optimization module: OptiPath

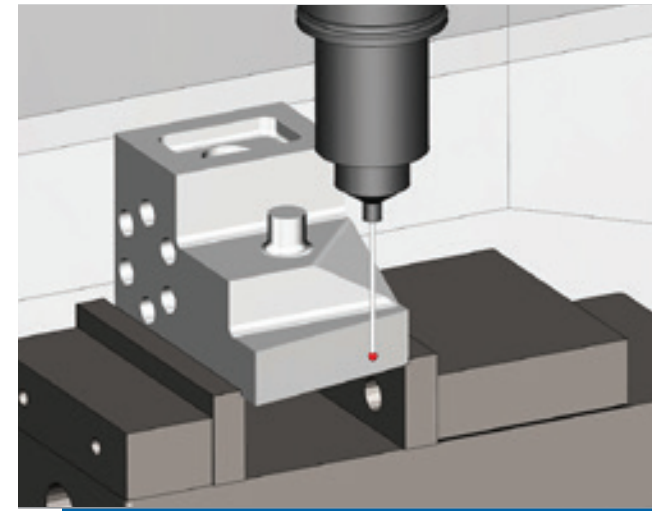

Probing

With VERICUT, there is no reason your probing operations should ever cause a headache! It notifies you when the probe tip contacts an object while not in 'probe mode,' and detects any collisions. It even verifies that the probe cycle's logic (which alters machine motion based on information gathered during probing) will not cause an error!

- Avoid probe collisions
- Simulate probing cycles
- Validate CNC probing processes

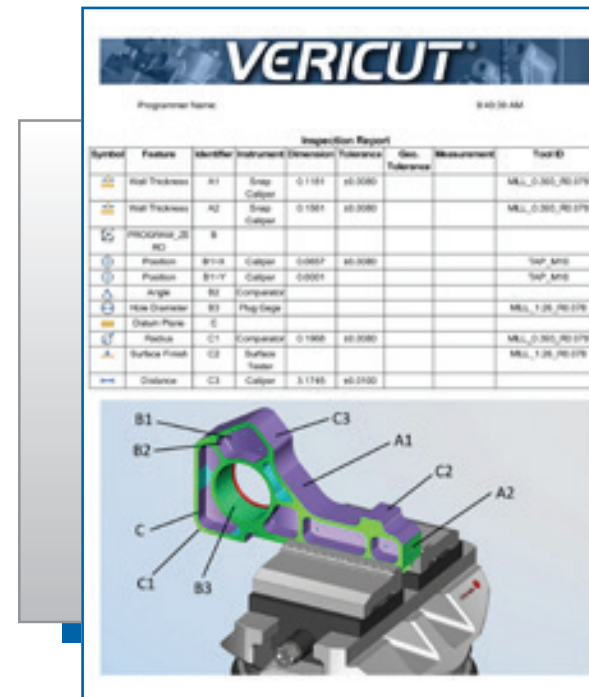

Shop Floor Documentation

With VERICUT Reports, you can establish a simple, efficient, and formal method to creating and documenting inspection and setup procedures.

- Customize any report with simple templates
- Add dimensions and notes to any report
- Export all reports to PDF or HTML

"I used Force on a program that I'd already optimized with a popular CAM system and Force lopped off (an additional) 40% of cycle time on the first go."

– John Giraldo, Aerospace Engineer, Sandvik Coromant

"I have about a 98% chance that the first part off the machine is a good part! VERICUT has saved us thousands of dollars and will continue to save us money."

– Charles Huffman, NC Programmer, Gibbs Machine & Tool

ADDITIVE MANUFACTURING

VERICUT's Additive module simulates additive and traditional machining capabilities of new hybrid CNC machines.

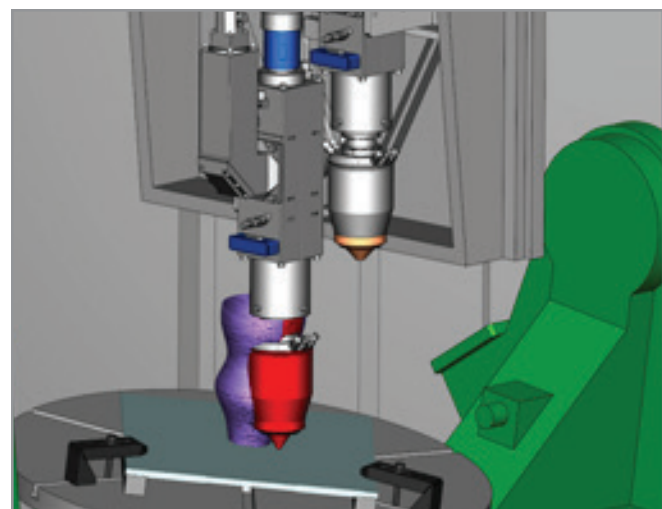
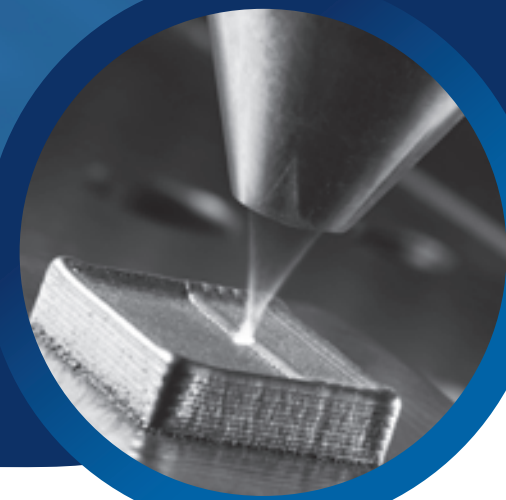

Verify Laser Activity & Detect Collisions

VERICUT's Additive module provides machine simulation for accurate laser cladding and material deposition. VERICUT detects collisions between the machine and the additive part, with its collision checking extended to cover additive parts as they are being built. VERICUT accurately checks for errors on all 5-axis milling, turning, and additive laser sintering processes, no matter how complex the operation.

- Identify errors, voids, and misplaced material
- Simulate G-code programs for hybrid machines
- Detect collisions between hybrid machine and additive part
- Verify laser activity, power, material feed, and gas flow
- Visualize realistic appearance of material deposition & machine features

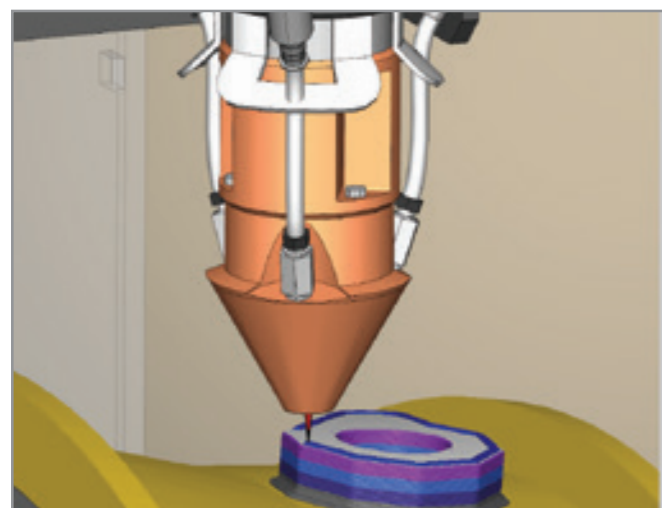

Hybrid Manufacturing

In VERICUT, additive operations are combined in any order with traditional "subtractive" machining, such as; milling, drilling, turning, etc. The realistic appearance of added material allows NC programmers to tell that all necessary machining has been performed.

COMPOSITE APPLICATIONS

Programming & Simulation software for Automated Fiber-Placement (AFP) and Tape-Laying (ATL) machines.

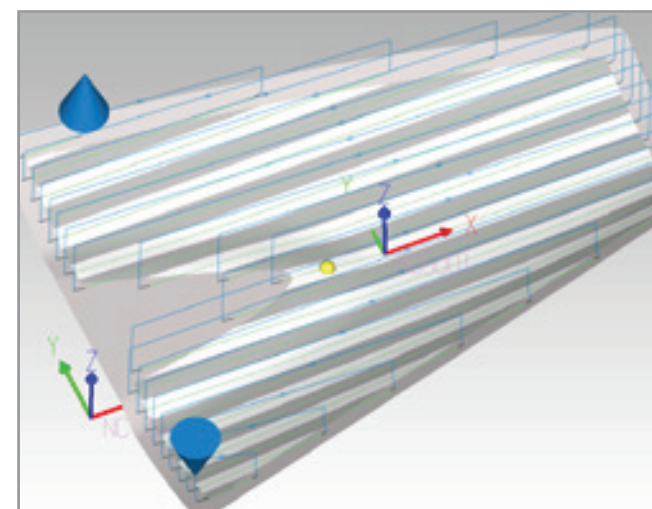

VERICUT Composite Programming (VCP)

VCP gives a composite part designer, mechanical engineer or process engineer access to the same software tools NC programmers use to create Automated Fiber-Placement NC program paths. From the designed model to the shop floor, VCP gives you control.

- Create NC code for ANY machine vendor!
- Create and experiment with AFP path options
- Generate layup paths based on engineering specs

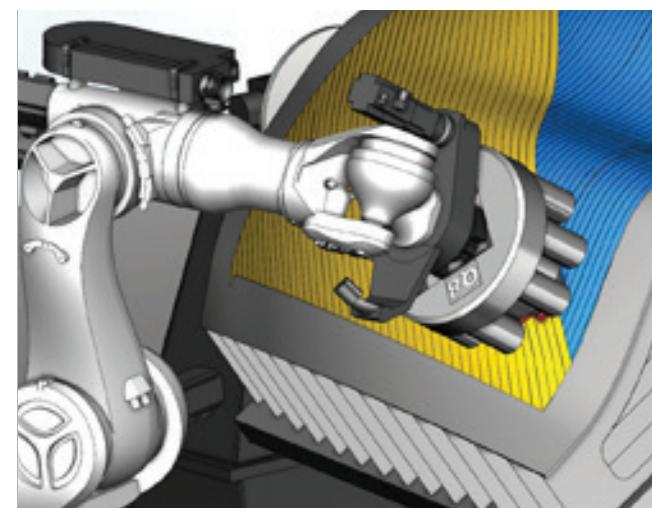

VERICUT Composite Simulation (VCS)

VCS simulates composite material being applied to the layup form via NC program instructions in a virtual environment. The simulated part can be measured and inspected to ensure the NC program follows manufacturing standards and requirements.

- Simulate your composite layup machinery
- Run composite NC machines right the first time
- Detect collisions & errors

"We looked at all of the major manufacturing software providers for their simulation capabilities and VERICUT was the only one that met our needs out of the box."

– Austin Kron, Managing Director, BeAM Machines

"There are occasions that we send our people home, turn the lights out and run our finished programs for the first time with nobody there. That's how confident we are in VERICUT!"

– Jerry Anthony, President, UCAR Composites, Inc.

DRILLING & FASTENING

VERICUT Drilling & Fastening (VDAF) is independent software that programs and simulates auto-drilling & fastening machines.

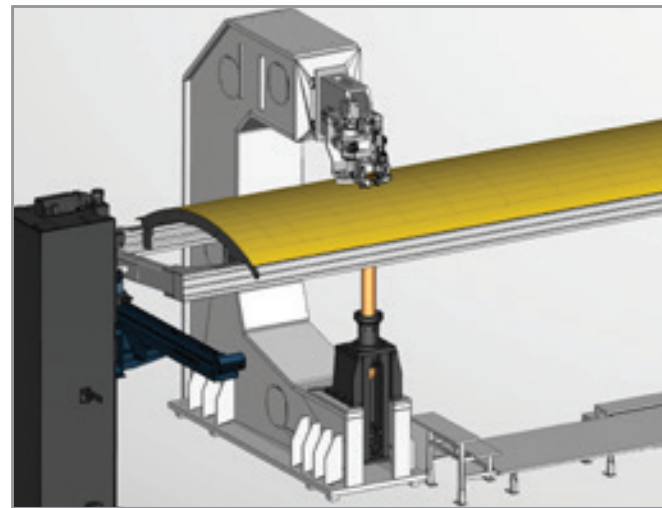

VDAF Simulation

Visualize and simulate CNC drilling and fastening machines using the same NC program code that will be run on the machine. VDAF can simulate NC programs from any programming system for any CNC automated drilling and fastening machine.

- Simulate machine motion directly from NC programs
- Avoid misplaced holes or fasteners and collisions
- A single license can simulate multiple machines

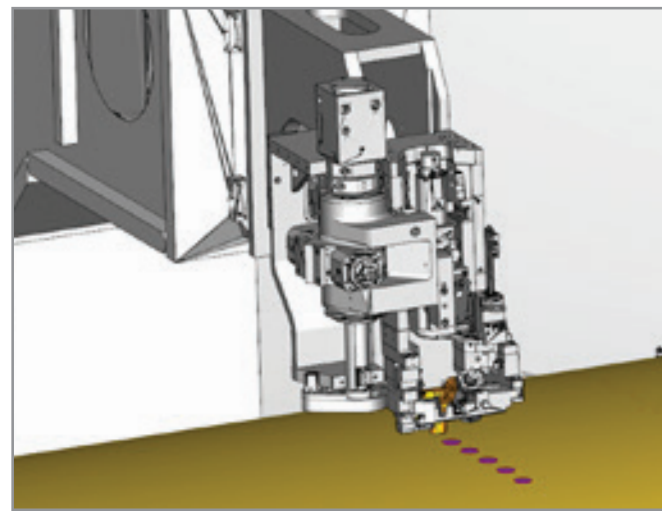

VDAF Programming

This add-on module to VDAF gives users the ability to create NC programs for CNC automated drilling and fastening machines.

- Easily create NC programs in a user-friendly interface
- Fasteners are easily grouped in a tree dialog
- A single license can program multiple machines

VDAF Helps you Avoid:

- Drilled holes or fasteners in the wrong position
- Missed holes or fasteners
- Collisions with structures, tooling, or added fasteners

"After running the tooling programs through VERICUT, we know they will be machined correctly."

– Eric Smith, Master Tooling Engineer, Jostens Inc.

VERICUT MACHINE CONFIGURATION (VMC)



VERICUT Machine Configuration (VMC)

To ensure that your virtual machine and real machine behave identically, a VMC is configured (by CGTech) to exactly match your machine tool. A true digital twin. CGTech has an extensive collection of VMCs that have been developed and maintained over many years. CGTech is able to provide VMCs for many of the leading Machine Tool Builders, often using CAD data supplied through our partnerships with the following companies:



"We run new NC programs unmanned overnight - after they have been tested with VERICUT."

– Paul Goresky, Senior Programmer, Tenneco Packaging Inc.

CAD/CAM INTERFACES

Integrate VERICUT and your CAM system(s) to easily create the most accurate and efficient NC programs possible!



CAD/CAM Interfaces

CAD/CAM interfaces make verifying and optimizing NC programs, and simulating CNC machines, a much easier and efficient process. All stock, fixture, and design geometry is automatically transferred to VERICUT in the correct orientation, along with your NC program, tooling, machine, control data, and other simulation parameters.



Tool Management Interfaces

Tool management interfaces extract tool lists from your tool manager system and create VERICUT tool assemblies. It is an on-the-fly live connection to your tool manager.



Model Interfaces

Model Interfaces enable VERICUT to read the designated model file formats and use them as stock, fixture, design, tool holder and machine models. When combined with Model Export, VERICUT's cut stock may be written out in these formats as well. The modules do not require a CAD/CAM system for VERICUT to read or write any of the formats.

TRAINING & SERVICES

VERICUT training is offered regularly at numerous locations. For more information, contact your CGTech representative or reseller.



Training

CGTech's hands-on training gives you the knowledge & skills to maximize VERICUT's potential. These courses are suited to NC programmers and CNC machine operators. After completing a course, you will be a better VERICUT user!

- Speedy implementation
- Regular classes at CGTech or customer sites
- Over 3 decades of CNC experience and dozens of skilled engineers available to you



Implementation & Contract Services

- VERICUT Machine Configuration
- NC Program Optimization
- CAD Model Export
- Custom Tool Libraries & Software Development

When you invest in VERICUT, you are teaming up with manufacturing industry experts that are committed to helping your company succeed.

Our dedicated staff of trainers, technical support engineers and developers are available to help you reach your manufacturing goals.

"VERICUT is an important part of our manufacturing process. Everything we program goes through VERICUT for verification before it goes to the shop."

– Hector Davis, Director of Mfg., ADI

"The savings on scrapped parts and material pays for the software many times over."

– Stan Boland, Systems & Programming Manager, Brek Manufacturing



CGTECH VERICUT®

CGTech Ltd.

Curtis House, 34 Third Avenue,
Hove, East Sussex BN3 2PD
TEL +44 (0)1273 773538
info.uk@cgtech.com
www.cgtech.co.uk

CGTech® is the leader in CNC machine simulation, verification, and optimization software technology. Since 1988, our products have been the standard in manufacturing industry sectors including; aerospace, automotive and ground transportation, mould and die, consumer products, power generation, and heavy industry. With subsidiary offices throughout Europe and Asia, and a global network of resellers, CGTech software is used by companies of all sizes, universities, trade schools, and government agencies.

CGTech maintains an active Technology Partnership program. VERICUT users in this program include many of the world's leading machine builders, CAD/CAM developers, and manufacturing software companies.



CGTech Worldwide

USA - Irvine, CA (Corporate Headquarters)
Brazil • China
France • Germany
India • Italy • UK
Japan • Russia
Singapore • South Korea

***When you invest in VERICUT, you're teaming up
with a manufacturing partner with the best
reputation in the business!***

